

750-965

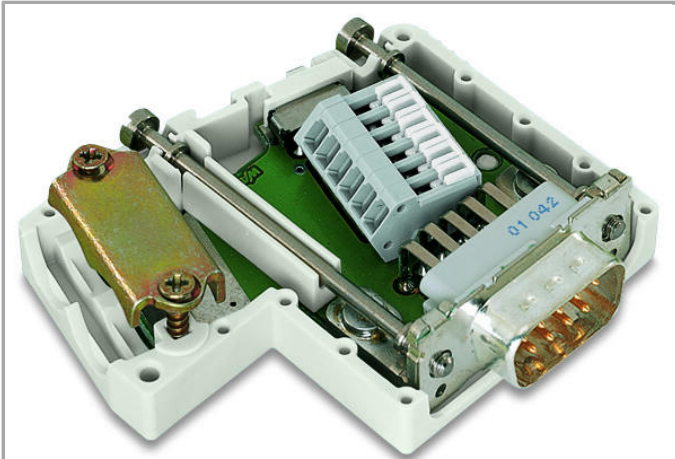

RoHS  Compliant

[BOMcheck.net](https://www.bomcheck.net)

Color:

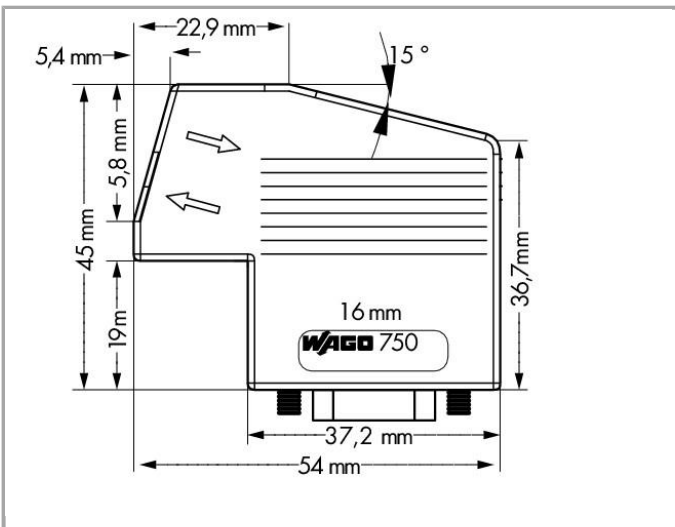
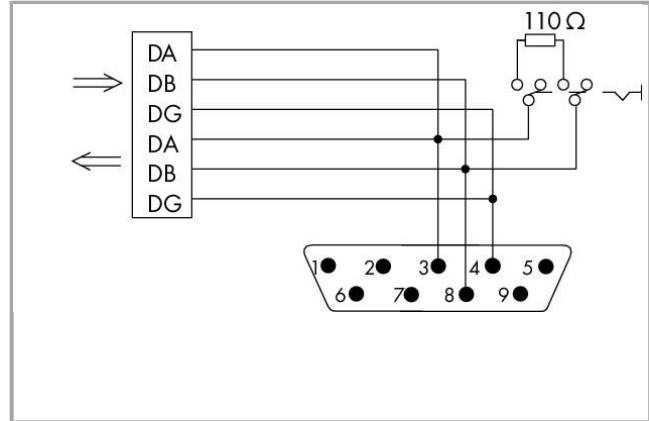

### Item description

The fieldbus connector connects a CC-Link device to a CC-Link line.

The fieldbus connector has the following features:

- 2 horizontal cable entries. One input and one output.



- Fast and maintenance-free CAGE CLAMP® connection, can be held in the open position with the help of an actuation slide mechanism.
- Externally operable switch to activate and/or deactivate the termination resistor.

For the first and last station on the bus, the switch must be set to "ON" (terminating resistor activated). Switch setting to "OFF" for the intermediate stations on the bus (terminating resistor deactivated).

## Data

### Technical Data

Connection type	Stecker D-Sub 9
No. of poles	9
Communication/Fieldbus	CC-Link
Baud rate	-

### Connection data

Connection type (1)	CAGE CLAMP®-Klemmleiste mit Betätigungsschieber (Serie 218)
Solid conductor	0.08 ... 0.5 mm <sup>2</sup> / 28 ... 20 AWG
Strip length	5 ... 6 mm / 0.2 ... 0.24 inch

### Geometrical Data

Width	45 mm / 1.772 inch
Height	16 mm / 0.63 inch
Depth	54 mm / 2.126 inch

### Mechanical data

Connectable sheathed cable diameter	4.5 ... 9.5 mm
Leitungseinführungen, Anzahl	2
Housing material	PA66-105-V2
Weight	34.1 g
Color	light gray

### Environmental Requirements

Surrounding air (operating) temperature	0 ... 60 °C
Surrounding air (storage) temperature	-25 ... 85 °C
Protection class	IP20
Relative air humidity (no condensation)	95 %
Fire load	0 MJ

### Commercial data

Product Group	15 (Remote I/O)
---------------	-----------------



Country of origin	DE
GTIN	4050821096030
Customs Tariff No.	85366990990

**Approvals / Certificates**

**UL-Approvals**

Logo	Approval	Additional Approval Text	Certificate name
	<b>UL</b> UL International Netherlands B.V. (ORDINARY LOCATIONS)	UL 508	E175199 Sec.1

**Downloads**

**Documentation**

**Bid Text**

750-965 IO, Feldbusstecker	Oct 2, 2014	doc 25.1 kB	Download
-------------------------------	-------------	----------------	----------

**Additional Information**

Disposal; Electrical and electronic equipment, Packaging	V 1.0.0	pdf 265.8 kB	Download
--	---------	-----------------	----------

Subject to changes.